

PEDAL ASSEMBLY IS COMPATIBLE WITH TILTON ENGINEERING 73, 74, 75 AND 76 SERIES MASTER CYLINDERS, SOLD SEPARATELY.  
75 SERIES MASTER CYLINDERS SHOWN HERE ARE FOR ILLUSTRATION PURPOSES AND ARE NOT INCLUDED WITH PEDAL ASSEMBLY.

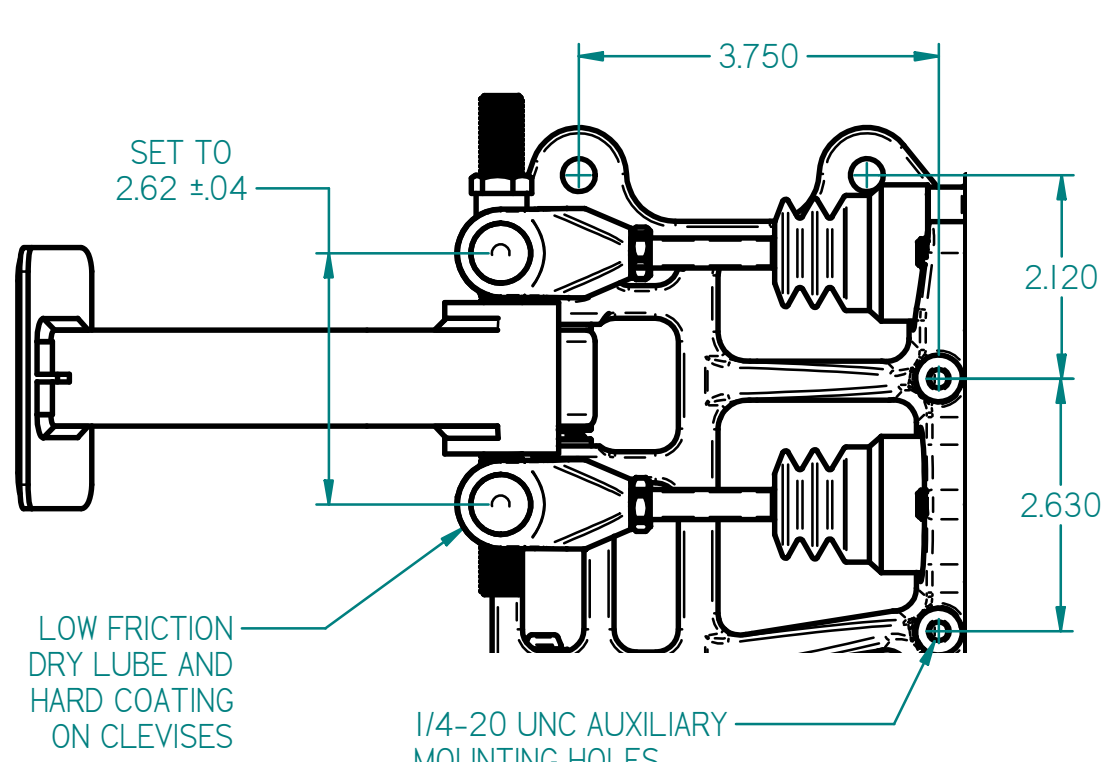
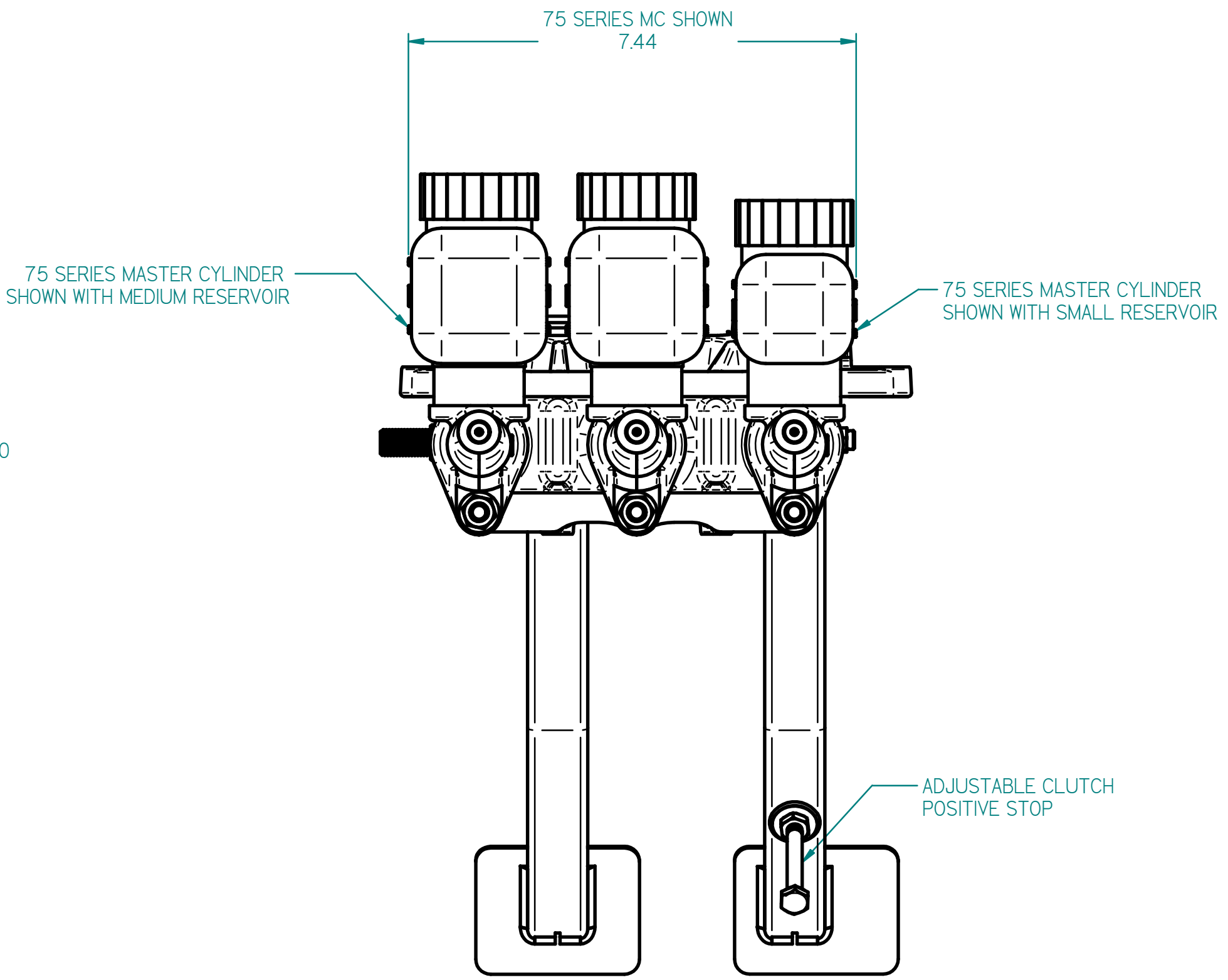
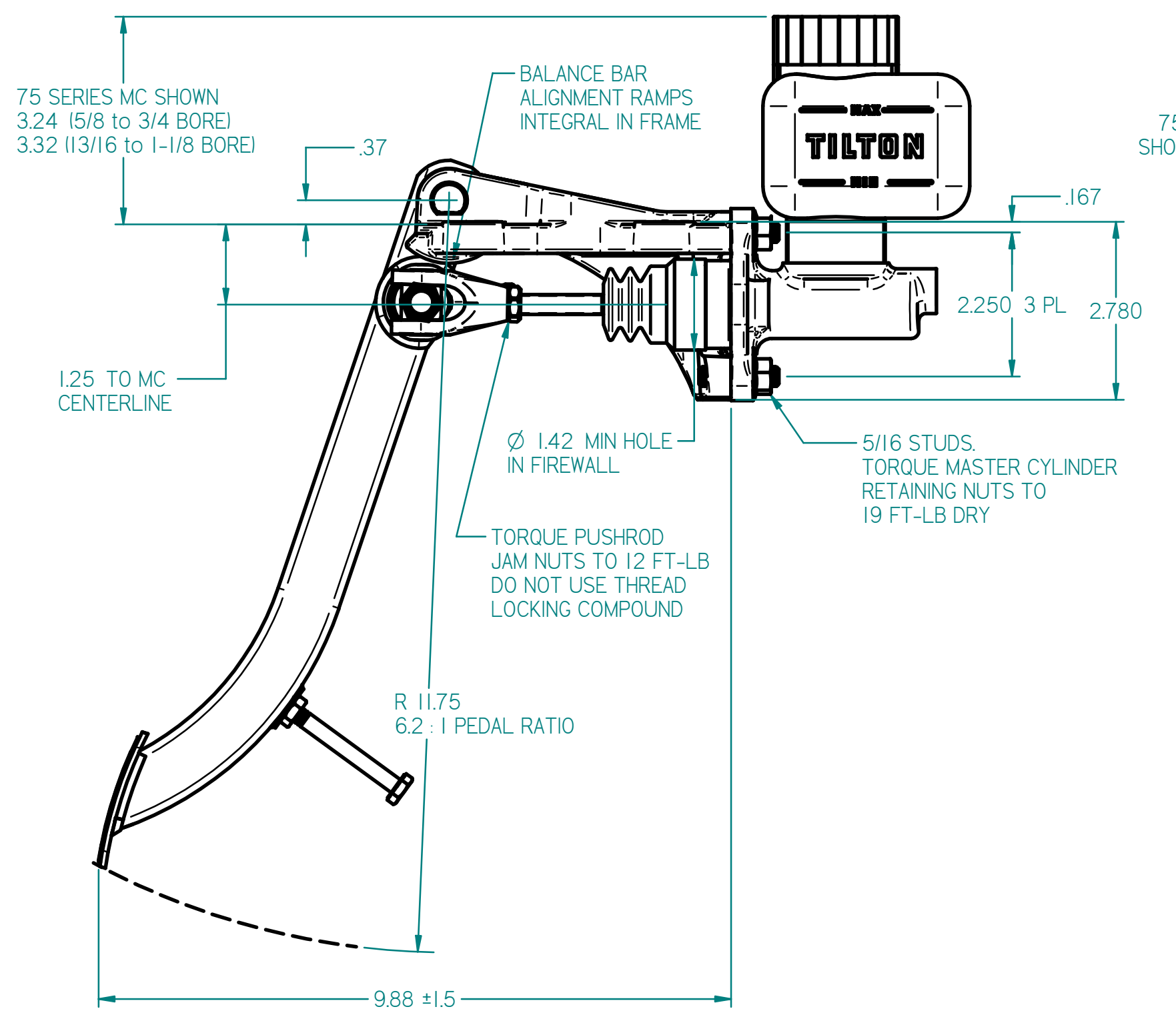
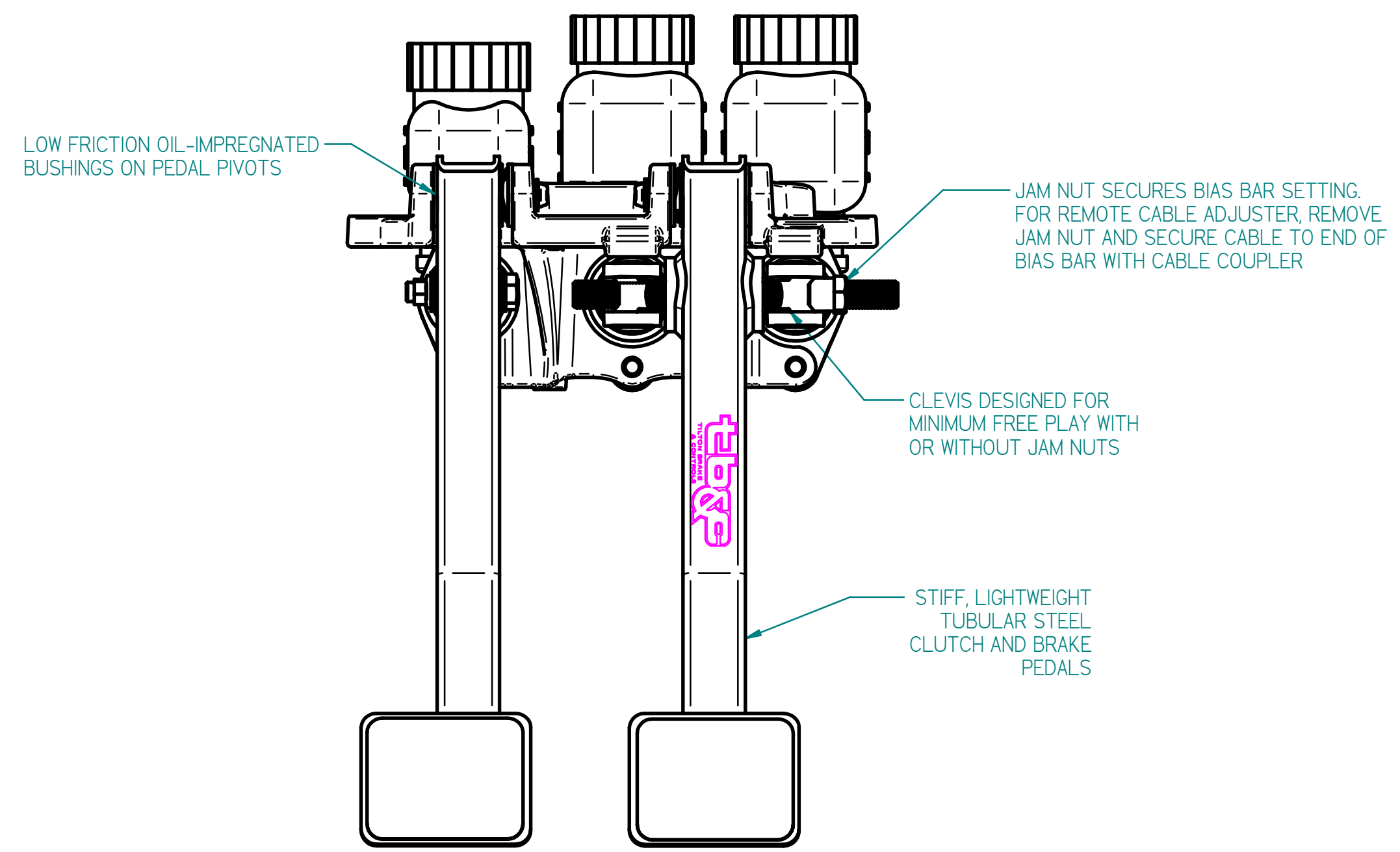
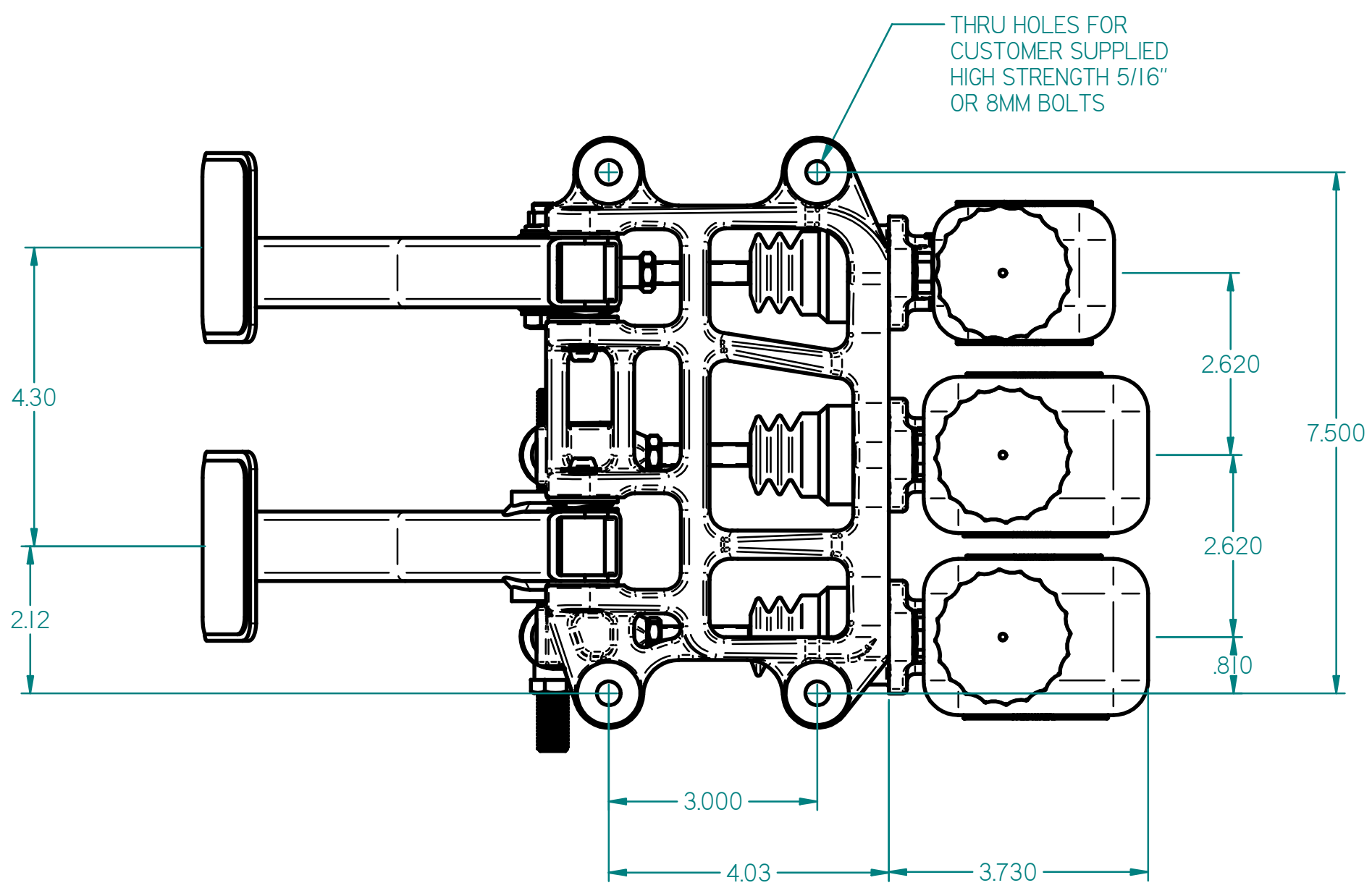

NOTES:  
1. UNLESS OTHERWISE SPECIFIED, ALL DIMENSIONS ARE INCHES  
2. DIMENSIONS ARE NOMINAL  
3. WEIGHT :

TOLERANCES: UNLESS SPECIFIED OTHERWISE		MATERIAL		TILTON ENGINEERING, INC. (805)688-2353 FAX (805)688-2745	
.X ±	DRILL HOLES	SPEC		25 EASY STREET P.O. BOX 1787 BUELLTON, CALIFORNIA 93427 USA	
.XX ±		COND		TITLE: INSTALLATION DRAWING	
.XXX ±		HARD		600 SERIES FIREWALL STEEL PEDAL ASSEMBLY	
FRACT ±		FINISH	DRN BY VAN SCHMUS	CHK'D O'NEIL	SCALE 1:2
ANGLE ±		SPEC	P/N 72-601	DATE 07/20/06	DWG 5123
CONC(TIR)					SHEET 1 OF 1

This document contains proprietary information of TILTON ENGINEERING, INC., and its receipt or possession does not convey the rights to reproduce, disclose its contents, or to manufacture, use or sell anything it may describe. Reproduction, disclosure, or use without specific written authorization of TILTON ENGINEERING, INC. is strictly forbidden.

**TILTON ENGINEERING** INC.